

Registration of electron and X-ray radiation sub-nanosecond pulses

*S.L. Elyash, T.V. Loyko, A.L. Yuriev, A.A. Seleznev**

*FSUE «Russian Federal Nuclear Center – All-Russian Research Institute of Experimental Physics», Sarov, Russia
al.al.seleznev@yandex.ru

Abstract. The characteristics of the electron beam generated by a subnanosecond accelerator with double sharpening in the voltage-pulse shaping circuit have been recorded. The duration of the electron-beam current pulse was 240–270 ps, the current amplitude was approximately 1.5 kA, and the maximum electron energy was approximately 0.95 MeV. The pulse-response characteristics of SPPD29k and SPPD29-02 X-ray semiconductor detectors were determined: their full widths at the half-maximum $\tau_{0.5}$ were approximately 320 ± 30 and 450 ± 30 ps, respectively.

Keywords: accelerator, gas-filled former, voltage subnanosecond pulses.

1. Introduction

To determine time resolution of nanosecond detectors of electron and X-ray pulses, to certify and control operability of measuring lines there was developed in RFNC-VNIIEF a sub-nanosecond accelerator of electrons with a gas-filled shaper [1]. As a source of nanosecond voltage pulses with the amplitude of ~ 0.9 MV there was applied a high-voltage block of accelerator ARSA. With the aid of a shaper nanosecond pulses were converted to high-voltage pulses of sub-nanosecond duration.

The current paper describes the case when the voltage at the output of the high-voltage block was increased up to 1.1 MV and additional sharpening was used in the shaper circuit what made it possible to shorten electron radiation pulse duration the amplitude of electron beam current remaining unchanged.

2. Sub-nanosecond gas-filled shaper

The design of a shaper with two sharpening gaps is available in Fig.1.

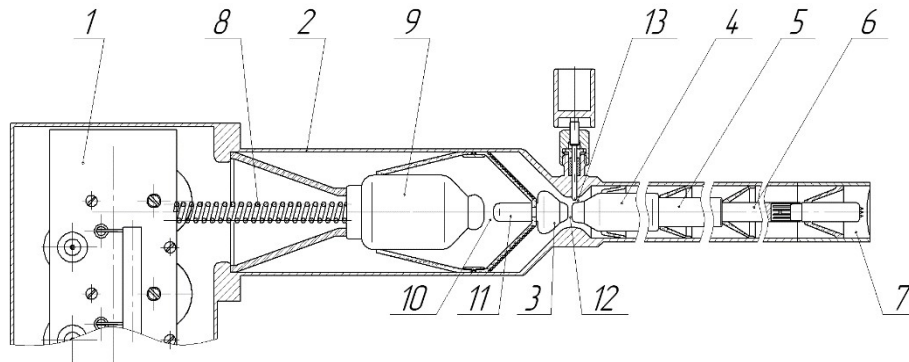

Fig. 1. Design of a sub-nanosecond pulse shaper: 1 – accelerator ARSA; 2 – sharpening unit; 3 – short storage line; 4, 5, 6 – sections of a stepped transmission line; 7 – accelerating tube; 8 – unbinding coil; 9 – forming line; 10, 12 – sharpening gaps; 11 – intermediate line; 13 – chopping gap.

The gas-filled shaper filled with nitrogen up to the pressure of 4 MPa is installed on the output branch pipe of the accelerator ARSA high-voltage block (1) and includes sharpening unit (2), short storage line (3) and stepped line divided to sections (4, 5 and 6) with wave resistance values 18Ω , 36Ω and 60Ω , correspondingly. The transmission line is connected to accelerator tube (7).

The shaper operates the following way. A voltage pulse with front duration $\tau_f < 10$ ns comes from the high-voltage block of accelerator ARSA to forming line (9) through unbinding coil (8). At gap breakdown of the first sharpening gap (10) there takes place the charging of the short storage line (3) during the time period $\tau < 1$ ns. After the line is charged up to the maximum voltage of ~ 1.1 MV,

the inter-electrode gap of the second sharpening gap (12) between the short storage line and transmission line is broken down and the short storage line is discharged to the matched with it first section (4) of the transmission line. Owing to the shortness of the storage line there is formed in the transmission line a sub-nanosecond voltage pulse, its amplitude being two times less than the charging amplitude of the short storage line. This pulse goes through the stepped line and enters the accelerating tube (7) generating electron radiation. For a gas-filled shaper there was specially developed and produced a vacuum sealed-off accelerating tube SNIT-1000 with ceramic insulator intended to be used under pressed gas environment. It is realized with distributed wave parameters and represents a part of the transmission line section (6) with the same wave resistance. A multipoint explosion-emission cathode diameter is 10mm. The output window of the tube made of titanium foil 50 μv thick serves as an anode.

The growth of wave resistance values in the stepped line sections as well as miscoordinated (unmatched) mode of the tube operation (its resistance is several times higher than the resistance of the transmission line last section) leads to the increase of the tube voltage amplitude practically up to the value of the short storage line charging amplitude. Chopping gap (13) is broken down at the maximal value of subnanosecond pulse voltage. It closes on itself the excesses of energy of the ARSA accelerator high-voltage block and shortens the subnanosecond pulse trail.

3. Calibration of registration channels

To register pulses of subnanosecond duration there were applied broadband registering channels. There were preliminarily measured transient characteristics of the cable and X-radiation registering channel with the aid of oscilloscope calibrator Fluke 9500V with various voltage pulses in the form of “a step” the rise time being (25 ± 4) ps and (70 ± 15) ps.

The registering channel involved a cable communication line (cable RK-50-4-21 ~5 meters long, cable RK-50-2-22 ~ 0.1 meter long) and a splitting capacitor – ceramic chip-capacitor (0.01 μF , 2 kV). The voltage was registered with the aid of a digital oscilloscope its bandpass being 5 GHz. The typical signal response oscillogram of the calibrator (rise time 25 ps) with the registering channel is presented in Fig. 2a.



Fig. 2. The signal response oscillogram of the calibrator (rise time 25 ps) with the registering channel – a (200 ps per square (for a square)) and the derivative of this signal – b.

At finding time resolution in pulse technology there are used both transient characteristic $h(t)$ – response to the step-function signal effect and pulse characteristic $g(t)$ – response to the effect of delta-pulse. They are related the following way:

$$g(t) = \frac{dh(t)}{dt}, \quad (1)$$

The half-height width $\tau_{0.5}$ of the pulse characteristic signal $g(t)$ that is more informative and demonstrable as compared to the transient characteristic $h(t)$ [2] is taken to be time resolution, thus the

measured transient characteristics were differentiated (Fig. 2b). The results of measurements and calculations are given in the Table 1.

Table 1. Measurement results taken from calibrator (rise time – 25 ps, 70 ps) and calculation results of pulse characteristics for the cable and registering channel.

Calibrator	Object of measurements	Front rise time, ps		Pulse duration of the differentiated transient characteristic, ps	Pulse characteristic (calculation), ps
		$\tau_{0.1-0.9}$	$\tau_{0.2-0.8}$	$\tau_{0.5}$	$\tau_{0.5}$
25 ps	no cable	108	73	115	–
	RK-50-4-21	138	90	125	49
	registering channel	203	125	160	111
70 ps	no cable	113	77	120	–
	RK-50-4-21	144	94	130	50
	registering channel	204	128	165	113

It follows from the Table 1 that the resolution time of cable RK-50-4-21 (length ~ 5 m) constitutes ~ 50 ps, while for the X-ray radiation registering channel it constitutes ~ 110 ps.

4. Amplitude–time parameters of subnanosecond electron beam

To register the current pulse shape there was used a monitor with a coaxial collector 3mm in diameter. The resolution of the similar device presented in paper [3] is ~ 25 ps. The signal was sent over cable RK-50-4-21 ~ 5 m long and registered by an oscilloscope (passband – 5GHz). The typical oscillogram of the electron beam current pulse is available in Fig. 3a. The duration of the registered electron current pulse at the amplitude half-height lies in the range (240–270) ps. The duration spread is basically related to the operation of the subnanosecond accelerator chopping gap. In terms of time resolution of the electron beam registration track the electron current pulse duration at the amplitude half-height constituted $\tau_{0.5} \approx (220 \pm 20)$ ps.

The electron beam current was measured using a current sensor consisting of a collector in the form of a disc (diameter 12 mm, thickness 1.5 mm) and low-inductance coaxial shunt assembled of twenty high-frequency chip-resistors connected in parallel (total resistance 0.3 Ω). The shunt was arranged near the output window of the tube. In connection with the amplitude limitation of the signal registered by a high-speed digital oscilloscope it is possible to measure only some share (portion) of the beam total current. The measurement was performed with the use of a diaphragm 2 mm in diameter placed on the window along the tube axis. The oscillogram of the electron beam current pulse is presented in Fig. 3b. The current amplitude constituted 45 A.

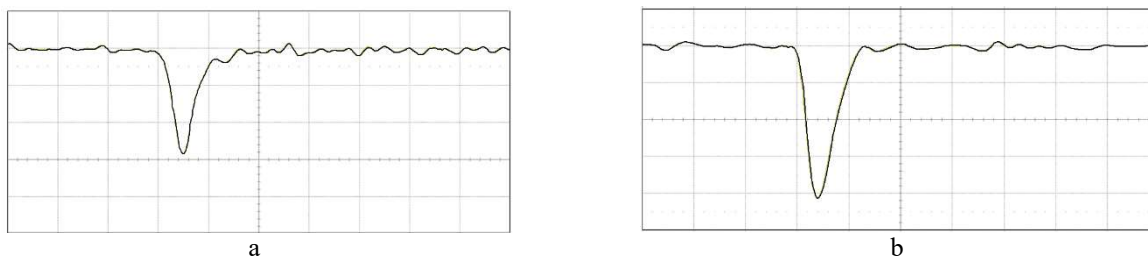

Fig. 3. Electron beam current oscillograms: a – monitor, b – current sensor (scan – 0.5 ns per cell).

To determine the total beam current value one should know how the current is distributed over the tube output window. For this purpose the beam autograph was registered per one pulse with the aid of dosimetric film SO PF(Eh) – 1/10. The electron current distribution over the electron beam cross-section was determined by film scanning (Fig. 4).

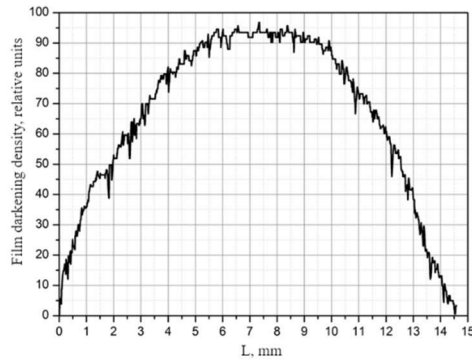

Fig. 4. Distribution of electron current over the beam cross-section.

It follows from Fig. 4 that the electron beam of subnanosecond accelerator has got axial symmetry conditioned by cathode design. The total electron current was determined in terms of the value of current measured through a diaphragm 2 mm in diameter and current distribution over the beam cross-section. The integration was performed numerically using a trapezium method. For this purpose the beam autograph was divided into concentric rings which number was defined by the number of image pixels. The value of the total electron beam current with the distribution as presented in Fig. 4 constituted ~ 1.5 μA .

The maximal energy of electrons was determined using a method of absorbing filters with the aid of a compact device for prompt estimation of electron energy [4]. The device was placed on the output window of the tube. A color film indicator TsVID-3 was used as electron detector. The maximal energy of electrons constituted ~ 0.95 MeV.

5. Registration of X-ray radiation subnanosecond pulses

As nanosecond high-voltage technology developed there appeared the necessity in registering high X-ray radiation fluxes of nanosecond duration what lead to occurrence of semiconductor detectors with subnanosecond time resolution. The generation of X-ray radiation in the subnanosecond accelerator took place at electrons deceleration in the external target (tantalum foil 50 μm thick) that was arranged on the output window of the tube. The electrons which passed through the foil were absorbed in the filter of aluminum 2 mm thick. The radiation was registered with the aid of CdTe-detectors (SPPD29k and SPPD29-02) [5]. The detectors were produced in connector case SR50-1FV. The case makes it possible to connect cable line with connectors SR50-74FV. The detector dark current at the operating voltage under normal conditions is not higher than 100 μA . The maximal pulse linear output current on the load resistance of 50 Ω at the 10%-deviation from linearity is not less than 0.5 A. The supply voltage is 1200 V. The detectors were located at a 3-cm distance from the tube window. The oscillograms of X-ray radiation pulses are given in Fig. 5a and 5b.

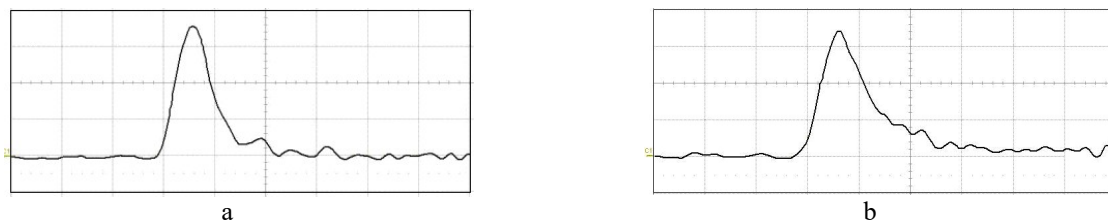

Fig. 5. Oscillograms of X-ray radiation pulses: a – SPPD29k, b – SPPD29-02 ((scan – 500 ps per cell).

The duration values of the registered pulses at the half-height of amplitude $\tau_{0.5}$ constituted (400–450) ps for SPPD29k and (500–550) ps – for SPPD29-02. In terms of calibration of registration

track and electron radiation duration the characteristics of semiconductor detectors SPPD29k and SPPD29-02 constituted at the amplitude half-height $\tau_{0.5} \approx (320 \pm 30)$ ps and $\tau_{0.5} \approx (450 \pm 30)$ ps, correspondingly.

6. Conclusion

The characteristics of electron beam generated by the subnanosecond accelerator with double sharpening in the circuit of voltage pulse formation are registered. The electron beam current pulse duration constituted (240–270) ps, the current amplitude is ~ 1.5 kA, the maximal energy of electrons is as high as ~ 0.95 MeV.

The duration spread is basically related to the operation of the subnanosecond accelerator chopping gap. In terms of time resolution of the electron beam registration track the electron current pulse duration at the amplitude half-height constituted $\tau_{0.5} \approx (220 \pm 20)$ ps.

There are determined pulse features of semiconductor detectors of X-ray radiation: SPPD29k and SPPD29-02, they are $\tau_{0.5} \approx (320 \pm 30)$ ps and $\tau_{0.5} \approx (450 \pm 30)$ ps, correspondingly.

7. References

- [1] A.L. Yuriev, S.L. Elyash, T.V. Loyko, S.P. Pukhov, D.P. Nikolaev, A.A. Seleznev, A high-current subnanosecond electron accelerator with a gas-filled former, *Instruments and Experimental Techniques*, vol. **60**(6), 853, 2017; doi:10.1134/S0020441217050128
- [2] Z.A. Al'bikov, A.I. Veretennikov, O.V. Kozlov. *Detectors of pulse ionizing radiation*. M.: Atomizdat, 1978.
- [3] E.V. Balzovsky, D.V. Rybka, V.F. Tarasenko, Features of recording the time profile of single picosecond pulses in the real-time mode, *Instruments and Experimental Techniques*, vol. **58**(5), 640, 2015; doi:10.1134/S0020441215050024
- [4] A.L. Yuriev, T.V. Loyko, S.L. Elyash, S.P. Pukhov, A device for prompt measuring of the maximum electron energy, *Instruments and Experimental Techniques*, vol. **57**(3), 87, 2014; doi: 10.7868/S0032816214020232
- [5] A.I. Polyakov, *Patent*, No 213765 RF. Class H01121/02//BI. 1998. No3.