

# Glow Nanosecond Discharge Xe, Kr, and Ar Plasma under High Pressure<sup>1</sup>

D.V. Rybka, M.I. Lomaev, E.H. Baksht, V.F. Tarasenko

*High Current Electronics Institute SB RAS, 2/3 Akademicheskoy Ave., Tomsk, Russia,*

*Phone: 7-3822-492-392, Fax: 7-3822-492-410, E-mail: [RDm@loi.hcei.tsc.ru](mailto:RDm@loi.hcei.tsc.ru)*

**Abstract – The emission properties of plasma in a nanosecond volume discharge under high-pressure xenon, krypton, and argon in a gap with a small curvature radius cathode have been investigated. Spectra in xenon in the range 120-850 nm and time-amplitude characteristics have been recorded and analyzed for various excitation regimes. It was shown, that at excitation by a volume discharge, initiated by an avalanche electron beam (VDIAEB), no less than 90% energy in the 120-850 nm range is emitted by Xe, Kr, Ar dimers. In xenon at pressure of 1.2 atm, the energy of spontaneous radiation in the full solid angle was ~45 mJ, and the FWHM of a radiation pulse was ~110 ns.**

## 1. Introduction

The volume pulsed discharges, taking place in various gases under high pressures are widely used for obtaining laser and spontaneous radiation [1, 2]. In order to form a volume discharge under pressure of tens – hundreds Torr and above, it is necessary to pre-ionize a discharge gap and produce the high initial electron density  $>10^{6-9}$  cm<sup>-3</sup>. The most popular sources of pre-ionization are UV and VUV radiation of spark and surface discharges, X-Ray radiation and electron beams.

Apparently, for the first time, volume discharges ("diffuse flashes") were obtained in [3] under atmospheric pressure air without an additional ionization source. Nanosecond voltage pulses with amplitude of 120-130 kV were applied to a gap with a small curvature radius. It was reported [4, 5] about availability in such discharges under atmospheric pressure of air of the specific deposited energies in the volume stage of 1 J/cm<sup>3</sup> and the specific input power of up to 800 W/cm<sup>3</sup> [5]. It was suggested [4] to name such discharge as a volume discharge, initiated by avalanches electron beam (VDIAEB). Besides the high specific input power, originality of VDIAEB is volume discharges availability under high pressures without external pre-ionization. In particular, in helium, the discharge was diffuse at pressure of up to 6 tm, and in nitrogen at pressure of up to 3 atm [5]. An additional interest in VDIAEB appears due to X-Ray radiation recording in the similar conditions [3, 5] and beams of subnanosecond runaway electrons [6, 7]. Just nowadays, the volume nanosecond discharges under high pressure of atomic and molecular gases in a non-uniform electric field, with a small curvature

electrode serving as a cathode, are widespread in many fields. In particular, such a discharge was used for pre-ionization in high-pressure lasers pumped by a self-sustained discharge [8] and lasing generation in Ar–Xe gas mixture [5, 9]. However, such discharges properties are still insufficiently explored, on account of, for example, short duration of discharge evolution, complex records of gap discharge current and voltage. The extended studies were carried out on VDIAEB optical characteristics in the range of 200–600 nm. So, the spectral and time–amplitude characteristics of radiation have been investigated in nitrogen and air, including the near–cathode dense plasma characteristics [10], and in neon, argon, krypton and gas mixtures of Ar–Xe and Ar–N<sub>2</sub> [9]. The inert gases radiation in VUV region was not investigated. Such investigation is of much interest for xenon due to its widespread application in creation of pulsed sources of spontaneous VUV and UV radiation, excited by a self-sustained discharge, as well as for creation of VUV-lasers based on Xe dimers, pumped by an electron beam [1].

This work was aimed at plasma emission properties study in a wide spectrum range of a volume nanosecond discharge formed under high pressure of xenon, krypton, and argon in a gap with a small curvature radius cathode without an additional ionization source. Generally, attention was paid to xenon radiation characteristics in the VUV spectral range.

## 2. Experimental setup and techniques

For the studies of discharge characteristics to be done, a special-purpose chamber and a gas system were developed. The set-up was used for discharge formation and the time-amplitude and spectral characteristics record of emission in the range from 120 to 850 nm. The schematic view of experimental setup is shown in Fig. 1. The discharge gap was applied with the voltage pulses from a RADAN-220 generator [11]. The generator with an impedance of 20 Ω formed a voltage pulse in a discharge gap with amplitude of up to ~220 V and FWHM of ~2 ns, at voltage pulse rise time of ~0.3 ns. A flat anode and a cathode with a small curvature radius used in the gas diode provided additional field gain in the near-cathode area. The flat anode was made of a brass plate, connected with chamber corpus by current shunt resistors. The cathode – anode spacing was varied from 4 to 16 mm.

<sup>1</sup> The work was supported by the funds of ISTC (Project No. 2706) and RFBR (Project No. 05-08-33621-a)

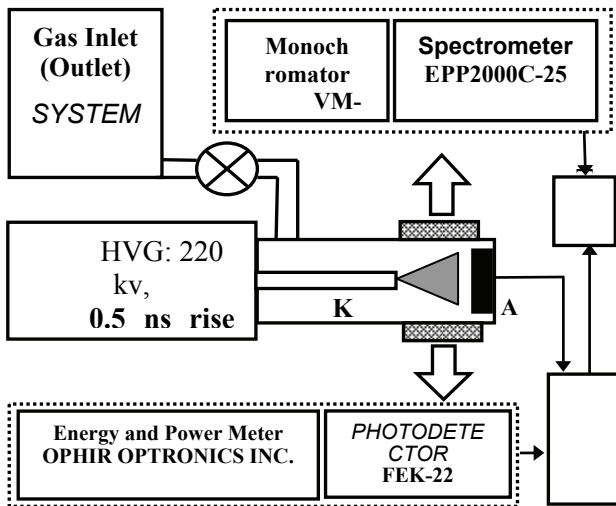

Fig. 1. Experimental setup:  
1 – discharge chamber, 2 – CaF<sub>2</sub> window, K – cathode, A – anode

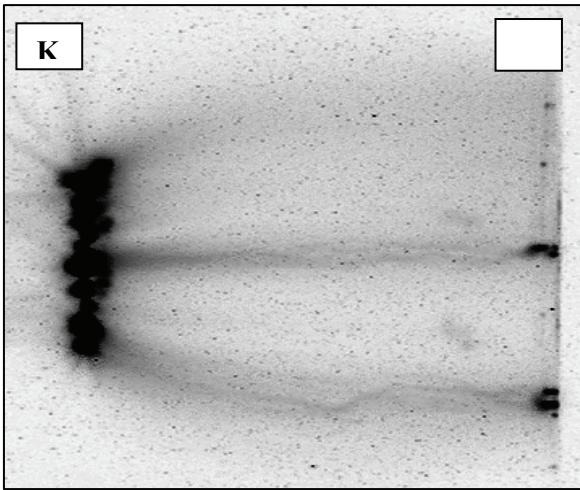

Fig. 2. A photograph of a discharge in xenon at pressure of 1.2 atm

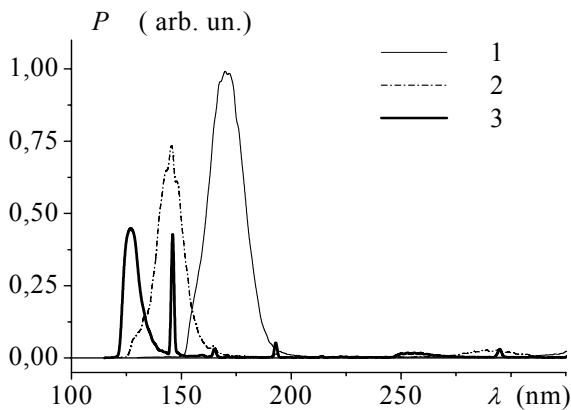

Fig. 3. Radiation spectra in Xe(1), Kr(2), Ar(3) at pressure of 1.2 atm at VDIAEB excitation

The gases were excited by VDIAEB, and xenon was also excited by a contraction discharge. The discharge had the contraction form due to the smaller discharge gap and a stainless cathode pointed with an angle of 60° used. The discharge glowing was photographed by a digital camera. The radiation spectra were taken by a spectrometer EPP2000C-25 (Stellar-Net-Inc.) with known spectral sensitivity in the range from 200 to 850 nm, and in the range from 120 to 540 nm radiation spectra were taken by a vacuum monochromator VM-502 (Acton Researcher Corp.). On spectra graphing from 120 to 850 nm, such spectra were sewed together, being obtained from the devices mentioned above for the wavelength range near 200 nm. Time evolutions of radiation were defined by photomultiplier tube (EMI 9781 B), which enables the signal leading edge of ~3 ns, and falling edge of ~30 ns, and a coaxial photodiode FEK-22 SPU with time resolution of ~1 ns. The TDS-3054 oscillograph with the time resolution of ~0.7 ns was used in experiments.

The energy of radiation was measured by a calibrated photoreceiver OPHIR OPTRONICS INC. with a PE50BB sensor head. The head was placed in a pumped volume within 10 cm from the longitudinal axis of the discharge gap. A point source model was used to calculate a share of radiation fallen to a photoreceiver at typical plasma formation size of ~1 cm.

### 3. Experimental results and discussion

VDIAEB has been initiated in Xe, Kr, and Ar under pressure of 0.3–1.5 atm without an external pre-ionization source. A photograph of the discharge glowing at 1.2 atm is shown in Fig. 2. The same as in the previous works, a diffuse (volume) discharge formed in the form of a cone or uniform jets. On the electrodes, foremost on the cathode, the bright spots were observed, which sizing did not exceed 1 mm. On VDIAEB formation, there was no any current surge of opposite polarity that testifies on the total energy transfer from the generator to the discharge plasma. The energy deposited to the discharge plasma in xenon at 1.2 atm was estimated as ~1 J. Such estimations were made on the basis of the energy stored in the high-voltage line of generator and short-circuit current. The specific input power in such conditions was no less than 100 MW/cm<sup>3</sup>.

The powerful wide bands of dimers in the VUV spectrum range were observed in all the inert gases, Fig. 3. The spectral half-width of the bands for Xe, Kr, and Ar at the pressure of 1.2 atm was, respectively, ~18, ~13, and ~8 nm. Wide band radiation in the UV and visible spectrum ranges has about two order smaller intensity. The radiant energy of Xe, Kr, and Ar dimers was no less 90 % with respect to the total energy of radiation in the range from 120 to 850 nm.

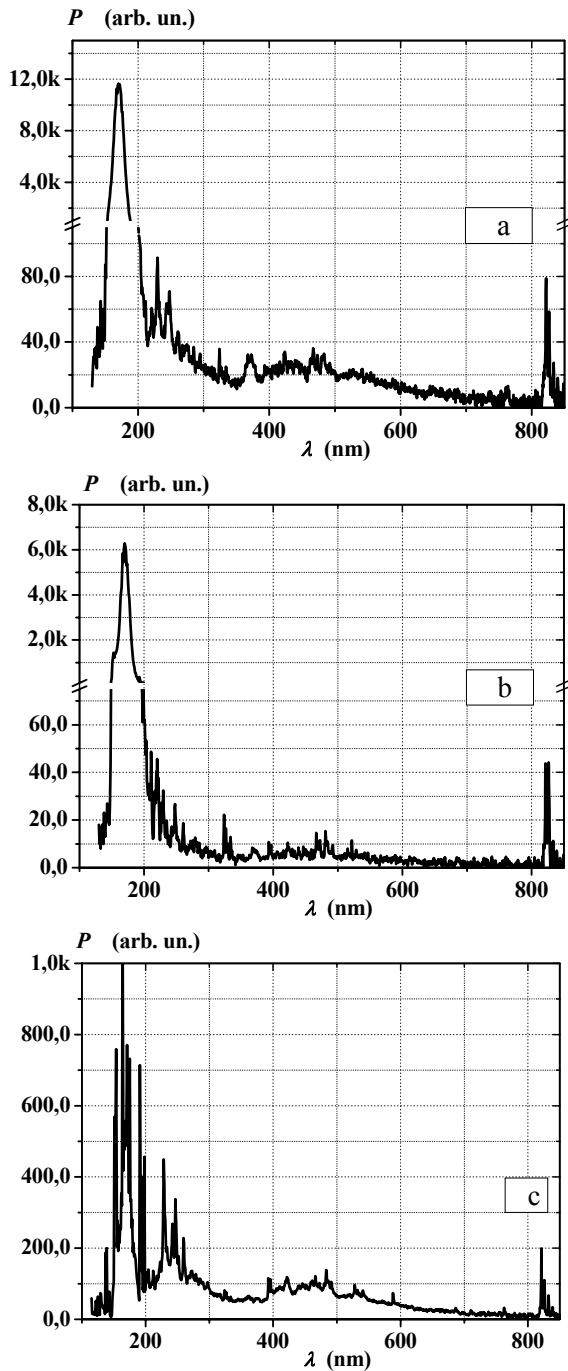

Fig. 4. A radiation spectrum of Xe in volume discharge at pressure of 1.2 atm (a), 0.3 atm (b); in contraction discharge, pressure – 0.3 atm (c)

The highest intensity of dimers was observed in xenon. As for Kr and Ar, the radiation intensity was, respectively,  $\sim 1.5$  and  $\sim 2$  times lower. Figure 3 shows the spectra, taking into account relative spectral sensitivity at  $\lambda = 126, 146,$  and  $172$  nm. A narrow line at  $\sim 147$  nm in Ar is probably a resonance line of xenon impurity at  $146.96$  nm.

In order to determine the effect of excitation method and discharge burning mode on the spectral

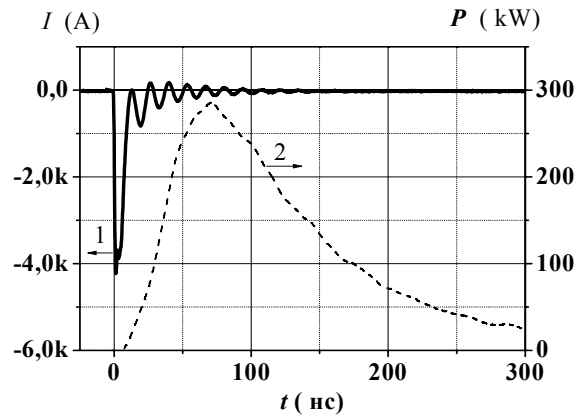

Fig. 5. Waveforms of current  $I(1)$  and VUV emission intensity  $P(2)$ ; Xe pressure – 1.2 atm

characteristics of plasma, radiation spectra in Xe were registered either at pressure varied from 0.3 to 1.5 atm and interelectrode spacing varied from 4 to 16 mm. Figure 4 shows the radiation spectra of a volume discharge (Fig. 4a, 4b at pressure 1.2 and 0.3 atm) and a contracted discharge (Fig. 4c at 0.3 atm) in xenon. It is seen that at VDIAEB excitation the type of a radiation spectrum weakly depends on pressure, the Xe dimer radiation is dominant ( $\lambda = 172$  nm). Radiation intensity in the UV and visible spectral ranges does not exceed  $\sim 1\%$  with respect to the peak intensity on dimer band at 1.2 atm. The time dependence of current and radiation pulses at  $\lambda = 172$  nm under Xe pressure of 1.2 atm in a volume discharge is presented in Fig. 5. Duration of a radiation pulse at FWHM is  $\sim 110$  ns. At the same time, duration of a wide band radiation pulse in the UV spectral range is essentially shorter.

As it is seen from the Figs. 4a, 4b the spectra of radiation of Xe being excited by VDIAEB at different pressures are similar, being essentially differing from radiation of a contracted discharge, Fig. 4c. For the contracted discharge, the major part of radiation falls on UV and visible spectral ranges from 200 to 600 nm. This radiation spectrum is similar to one of the well-known pulsed Xe lamps.

We believe that the use of VDIAEB is rather perspective in creation of short-impulse powerful spontaneous radiation sources in the VUV spectral region. While measured by an OPHIR calorimeter, radiation energy to the full solid angle was  $\sim 45$  mJ and pulsed radiation power was  $\sim 300$  kW at Xe pressure of 1.2 atm. Such a device maybe used, for example, for  $\text{XeF}_2$  dissociation in optical pump XeF-laser active medium on C-A transition [12]. Note, that these are not limit values of radiation energy and power for this device. The measurements of energy and power of Xe dimers radiation show the lower values since a part of excitation energy was lost with shunting discharge from a cathode holder to corpus.

The use of VDIAEB in creation lasers based on inert gases dimers either seems to be perspective too. It is highly important that at excitation by short pulses an optimal regime is realized in a plasma laser pumped by a self-sustained discharge [13]. An excitation pulse is several nanoseconds, and generation should be observed in afterglow, when active medium absorption at laser wavelength is decreased.

We suppose that in the examined conditions the following dynamics of formation of a volume discharge in a gap with a small-curvature radius is realized, see [5, 14]. On application of a voltage pulse the cathode electric field is gained. There is a gain of the electric field also due to cathode spots formation on plasma blobs due to explosive electron emission. Due to electric field gain and the high voltage increase in a gap during a voltage pulse rise time, the part of electrons in the near-cathode area passes to "runaway" mode, being accelerated up to the energies units – tens of keV (the fast electrons). The electrons possess the energies, higher than the energies corresponding to a maximum of ionization section, and while they move to anode preliminary gas ionization is realized. Thus formation of a volume discharge in a gap at a non-uniform electric field is determined by a gap pre-ionization by the fast electrons, which are generated due to the field acceleration on the cathode, cathode spots, and in the gap, as well as by overlap of electron avalanches, which density is maximal in the near-cathode of a discharge gap.

#### 4. Conclusion

At excitation of inert gases by VDIAEB, the main part of energy in the range of 120–850 nm is emitted by dimers of inert gases. Excitation by VDIAEB has prospects in creation powerful short-pulsed sources of spontaneous VUV radiation. Such devices may be used, in particular, for photolytic pump of lasers for

obtaining powerful femto-second radiation pulses [12]. VDIAEB might be either used in creation active media based on inert gases dimers for VUV electro-discharge lasers.

#### References

- [1] H. Roudz, *Excimer lasers*, Moscow.: Mir, 1981.
- [2] A.A. Kuznetsov, V.S. Skakun, V.F. Tarasenko, E.A. Fomin, *Tech. Phys. Lett.* **19**, 133 (1993).
- [3] L.V. Tarasova, L.N. Khudyakova, *J.Tech. Phys.*, **39**, 1530 (1969).
- [4] V.F. Tarasenko, V.M. Orlovskii, S.A. Shunajlov, *Izv. Vyssh. Uchebn. Zaved.: Fizika* **3**, 94 (2003)
- [5] S.B. Alekseev, V.P. Gubanov, I.D. Kostyrya, V.M. Orlovskii, V.S. Skakun, V.F. Tarasenko, *Quantum Electronics* **34**, 1007 (2004).
- [6] L.V. Tarasova, L.N. Khudyakova, T.V. Loiko, V.A. Tsukerman, *Zh. Tekh. Fiz.* **44**, 564 (1974).
- [7] V.F. Tarasenko, V.G. Shpak, S.A. Shunailov, I.D. Kostyrya, *Laser and Particle Beams* **23**, 545 (2005).
- [8] S.N. Buranov, V.V. Gorokhov, V.I. Karelin, A.I. Pavlovskii, P. Repin, *Quantum Electronics* **18**, 891 (1991).
- [9] I.D. Kostyrya, V.S. Skakun, V.F. Tarasenko, A.V. Fedenev, *Technical Physics* **49**, 987 (2004).
- [10] L.P. Babich, T.V. Loiko, L.V. Tarasova, *Pribori i Tekhnika Eksperimenta* **1**, 203 (1977).
- [11] P.Y. Zagulov, A.S. Kotov, V.G. Shpak, Y. Y. Yurike, M. I. Yalandin, *Pribori i Tekhnika Eksperimenta* **2**, 146 (1989).
- [12] V.I. Tcheremiskine, M.L. Sentis, L.D. Mikheev, *Appl. Phys. Lett.* **81**, 403 (2002).
- [13] L.I. Gudzenko, S.I. Yakovlenko, *Plasma lasers*, Moscow.: Atomizdat, 1978.
- [14] V.F. Tarasenko, S.I. Yakovlenko, *Physica Scripta* **72**, 41 (2005).